

# TECHNICAL DATASHEET



## EF TAPPING SADDLE

04 Update - 05/2024

### TECHNICAL DATA

Article No	001 117 2071 0208
d (mm)	200
d1 (mm)	63
le (mm)	100
h (mm)	268
h1 (mm)	125
Z (mm)	194
L (mm)	140
Weight (Kg)	1,200
Box Quantity (pcs)	4
Box Dimension (cm)	55x30x37,5

### INJECTION MOULDED

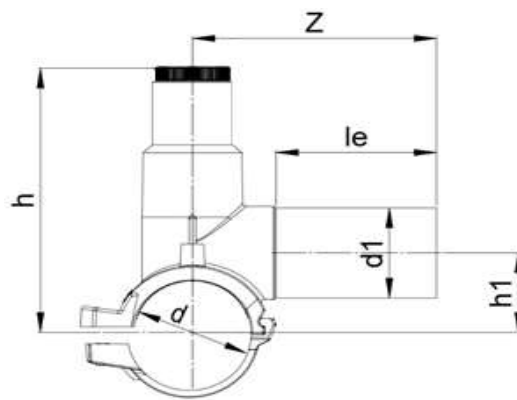

### IDENTIFICATION OF PRODUCT

D(mm)	200-63
SDR	11
RAW MATERIAL	PE 100
PRESSURE CLASS	16 Bar Water 10 Bar Gas
TRADEMARK	NTG
EXECUTION	Injection Moulded
STANDARD	EN 12201-3 EN 1555-3 AS / NZS 4129

SPECIFICATION	Suitable for SDR11.....17 pipe Injected monobloc type 4 mm pin connectors Long Fusion outlet Hexagon wrench 12 mm O-ring sealed screw cap
---------------	--

### EF SPECIFICATION

WELDING VOLTAGE	40 V
RESISTANCE	7,0 $\Omega$
WELDING TIME	130 Sec.
COOLING TIME	15 Min.
WINDING TYPE	Monofilar
WELDING BARCODE	



941420324083407005130118

Tolerance on diameters and thickness according to the standards. The other dimensions are specialized. Tolerance  $\pm 5\%$ . NTG PLASTIK reserves all the right to change any information without giving prior notice. The production, distribution and utilization of this document without explicit authorization is prohibited.